

# Medical technology

**FESTO**





**You develop high-end medical technology.  
You expect solutions that meet your specific needs.  
We deliver customised and value-adding solutions.**

**→ WE ARE THE ENGINEERS  
OF PRODUCTIVITY.**

**Be more productive – it's a matter of selecting the right partner**

From the initial concept and mutual development, right on up to delivery of customer-specific components and subsystems – we're your partner.

**Risk management in medical technology**

With Festo, you don't take any chances where approval and certification of your medical devices are concerned, because Festo adheres to the ISO 13485 directive and FDA requirements when developing products for technical, medical devices. Festo is always in tune with valid processes, documentation and materials during product development: from the identification and assessment of risks to the definition of risk-reducing measures.

For more information:

**[www.festo.com/medtech](http://www.festo.com/medtech)**

## Equipped by Festo

We supply reliability: you integrate additional safety into your systems and devices with our reproducible subsystem solutions.

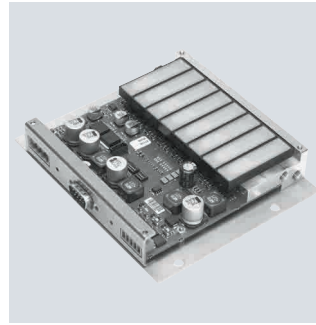

### Gas handling

- Piezo valves for metering oxygen and respiratory gases
- Pressure regulation for compression therapy
- Pneumatic operation of surgical instruments



### Liquid handling

- Handling of liquid media, e.g. for pipetting and dosing
- Dosing and drawing off of liquids in ophthalmological surgery

Our  
subsystems

Your ideal  
solution

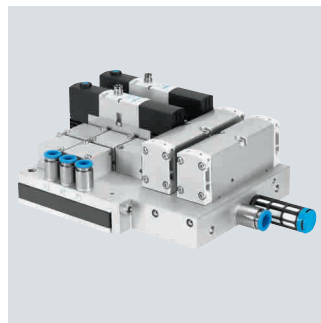

### Control units

As ready-to-install solutions with solenoid valves, pressure regulators, piezo valves and tubing

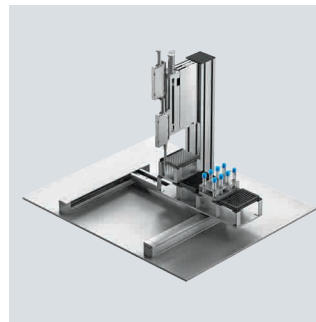

### Handling systems

- Automated specimen preparation
- Handling of specimens in medical diagnostics

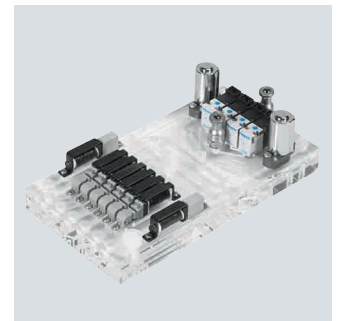

### Function solutions with integration technology

- Valves, pumps and sensors are integrated onto manifold duct plates made of various materials, in order to implement analytical processes.
- Micro-fluidic systems for lab-on-a-chip applications

## Therapy systems

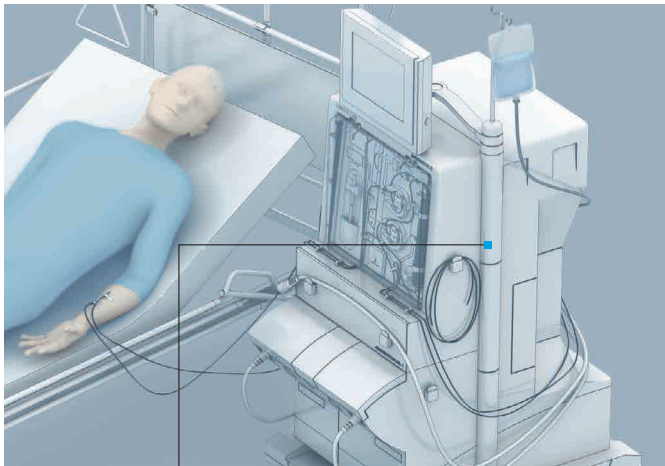

### Dialysis

#### Regulation and control of liquid flow

Precision regulation of all involved flowing fluids from the circulatory system (primary circuit) and the dialysis circuit (secondary circuit) is decisive for efficient dialysis.

Many various components are used in order to control these fluid circuits, amongst others pumps, media valves and pneumatic valves, piezo valves used as proportional precision pressure regulators, tubing and connectors, pressure and temperature sensors, as well as blood, dialysate and anticoagulant pumps.

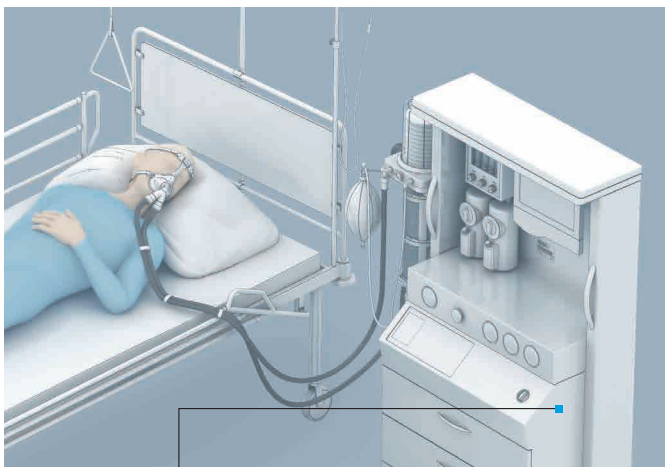
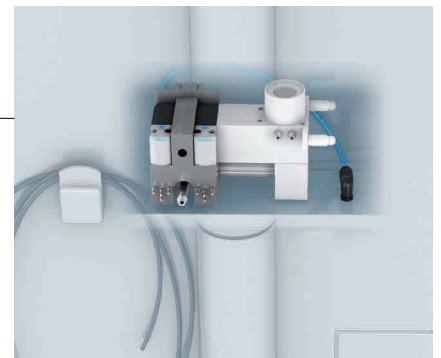

### Oxygen therapy, ventilation treatment

#### Regulating gas flow and pressure

CPAP ventilation (continuous positive airway pressure) combines the patient's spontaneous breathing with a continuous, controlled overpressure. It's used in intensive care, as well as for the treatment of sleep apnoe and in oxygen therapy.

Compact, lightweight and portable for greatest possible mobility, and quiet for pleasant operation: made possible by controlled valves which dose oxygen in accordance with the needs of the patient, and thus avoid unnecessary consumption. High quality tubing and connectors contribute to a long service life.



## Surgical instruments

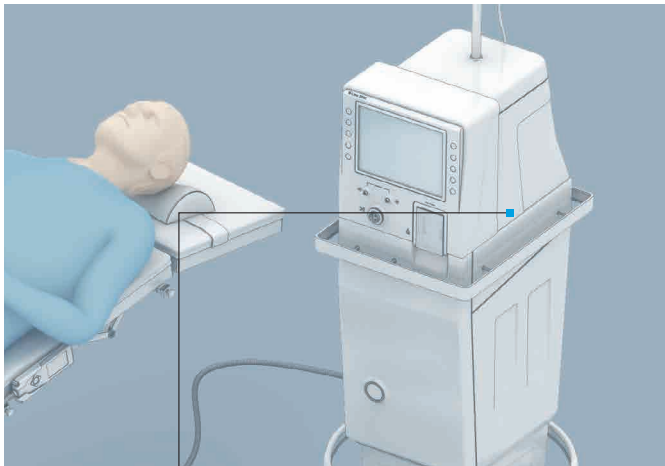

### Ophthalmology

#### Control of pneumatically operated surgical instruments

Surgical instruments used in ophthalmological operations are pneumatically powered. Solenoid and piezo valves regulate pressure and vacuum. Various liquids and gases have to be handled as well.

A pneumatic control unit executes the following functions:

- Pneumatic powering of the surgical instruments
- Vacuum-aided aspiration for cleaning the surgical field
- Conveyance of liquid media



### Dental station

#### Regulation of fluid flow, gas flow and sludge

The service units next to dentists' chairs are usually pneumatically powered. Many standard dental treatments (including mobile treatments) would not be possible without being able to control liquid flow, gas flow and sludge.

The various treatment instruments at dental service units are controlled independently of one another by switching valves, proportional valves, pumps and compressors. A compressed air controller regulates drill speed in the dental turbine.

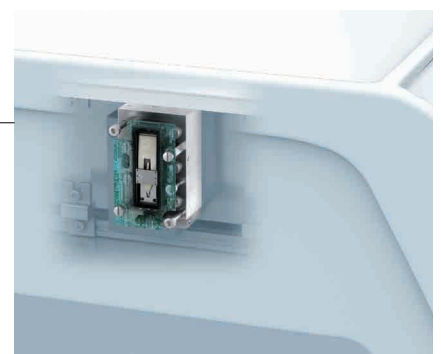

## Medical equipment

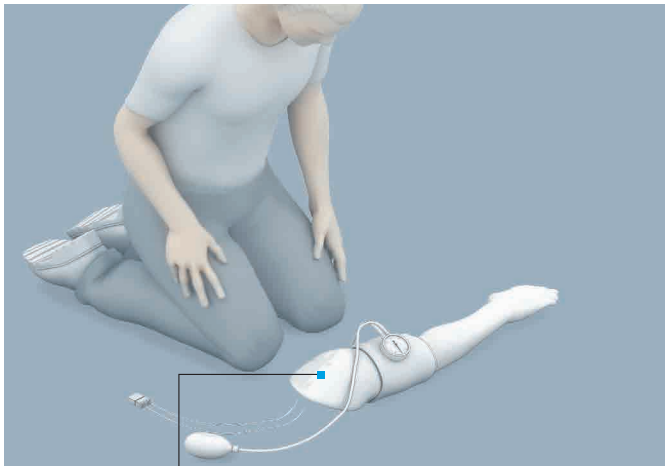

### Training torsos

#### Regulating fluid flow

Medical applications are practiced realistically during medical training with the help of so-called mannequins, for example the cardiac massage and the measurement of blood pressure.

Software for intelligent control and hardware are coordinated with each other in order to simulate breathing, pulse rate and bodily fluids such as tears. Movement of air and liquids can be simulated in this way

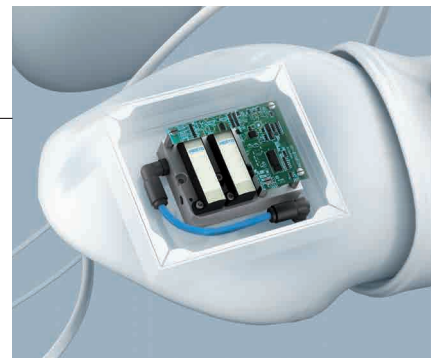

### Medical mattresses

#### Regulation of gas flow and pressure

People who are confined to bed have to be repositioned frequently in order to avoid bedsores. Automated control of pressure and gas flow in special anti-decubitus mattresses is also used to manually reposition patients, and thus supports patient care.

Piezo valves actuate the chambers individually. Thanks to their extremely minimal operating noise, they ensure gentle and quiet pressure changes by means of their proportional characteristics with soft-start function.

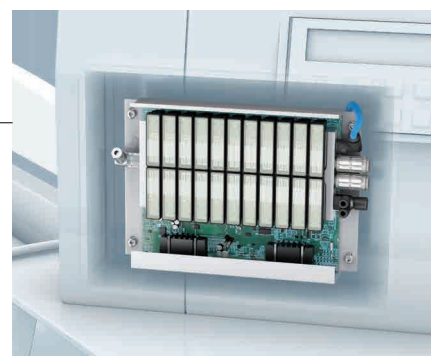

## Diversity for a wide variety of tasks



### Piezo valves VEMR/VEMC

The VEMR controls flow rates, for example in oxygen therapy devices for targeted supply and dosing of oxygen during inhalation. Combined with a flow sensor it's transformed into a proportional flow control valve.



The VEMC regulates pressure, for example when used in lymph drainage devices. Combined with a pressure sensor, it's transformed into a proportional pressure regulator.



### Solenoid valve MH1

Compact, 4 ms switching time, flow rates of up to 14 litres per minute, 100% duty cycle: the 2/2 or 3/2-way valves are ideal for standard valve functions and vacuum applications, as well as for pilot control of process valves which come into contact with media. The MH1 is available as an individual valve, or pre-mounted to a sub-base with extremely high component density.



### Diaphragm solenoid valve VODA

With extremely small internal volumes and nominal sizes from 0.4 to 6.0 mm, utilised materials depend on the medium. NC and NO variants, as 2/2 or 3/2-way valves.

- Various materials, best possible resistance to chemicals
- Short switching times, precise metering

### Proportional pressure valve terminal VEMA

A great piezo solution which integrates its own sensors, controllers and control circuits! 8 tightly packed VEMC valves require only a fraction of the space necessary for solenoid valves, because no dangerous heat is generated.

- Easy installation thanks to central vacuum and pressure supply
- CAN-Bus control: easy to connect with valve terminals or other devices
- Optional: LEDs



### Electric automation platform CPX

The first platform for extending automation into the fieldbus level. Fieldbus nodes, remote I/Os (digital/analogue), compressed air and gas sensors, motor controllers, front-end control, condition monitoring, measuring, regulation and counting.



### Compact controller CECC

The compact controller CECC provides lots of functions at a low price. As a standalone or integrated into mechatronic solutions via CoDeSys V3, it's easy to integrate into master systems via Modbus/TCP.



### Tubing-fitting combination PFAN/NPCK

Everything from a single source – the right combination for every task: the enormous number of possible combinations ensures maximum flexibility for standard applications. For temperatures from -20 ... 120° C and pressure up to 12 bar.



### Benefit from the positive characteristics of piezo technology

The trend is moving towards ever smaller and lighter medical devices. At the same time, they have to withstand the stress of routine daily use for long periods of time. Piezo technology is one of several key technologies offered by Festo to this end.

### The advantages at a glance:

- No operating noise
- No generation of heat
- Good energy efficiency
- Minimal weight
- Proportional characteristics
- Very short switching times
- Compatible with oxygen
- Sturdy and durable

## Added value during all phases of the product lifecycle

### Engineering/validation

Optimised production costs.



Festo

- Provides you with the advice you need for achieving more efficient solutions and maximised standardisation
- Saves you time in engineering
- Provides you with support for optimum planning and implementation
- Coordinates all of this for you with all other involved partners
- Worldwide – even for cross-border projects!

### Procurement

Everything from a single source.



Festo supplies:

- Products, as well as special and complete solutions ranging from
- Standard pneumatics through ready-to-install, customer-specific solutions and
- Coordinates your international activities with the help of a closely-knit customer service network at 250 locations in 176 countries

### Installation

Save time and money.



Benefit from Festo plug & work thanks to:

- Tested, ready-to-install products
- Integration into medical devices

### Qualification

Safe operation.



Festo supports you with:

- Risk management as an integral part of product development
- Reduced expenses for approval and certification

## Innovation through synergies

### Biotechnology and pharmaceuticals industry



### Laboratory automation



### Food and beverage industry



For years, Festo has been developing factory and process automation solutions for a broad range of industry sectors. By transferring our experience and innovations from one industry to another, we take advantage of valuable synergies and create economies of scale.

You too can benefit from our worldwide network of know-how, because it enables us to develop and implement customised concepts for your system quickly and economically.

### We are the engineers of productivity

There are four outstanding characteristics with which we successfully implement your automation tasks and provide you with increased productivity: security, efficiency, simplicity and competency. These make us what we are for you: engineers of productivity.